



SPECIALISED TOOLS
AND EQUIPMENT

"Makin' the Hard Jobs Easy"

ELEPHANT

ELECTRIC CHAIN BLOCK



3 Phase FA type SINGLE SPEED • **FB type** DOUBLE SPEED
1 Phase SA type SINGLE SPEED

No.2

High quality & efficiency
World class advanced chain hoist

Simple structure & useful



ELEPHANT CHAIN BLOCK CO.,LTD.



OPTION:OVERLOAD LIMIT DEVICE

Model:FA III FB III SA III

New type of overload limit device(Torcon) is the slip clutch equipped to motor.
In case of overloading, it actuates and stop the hoist lifting the weight. This mechanism protects the hoist from damage due to overload.

SA model

Features

1.Single phase class B insulation

Short time duty:25minutes

2.Thermal protector

Thermal protector senses the abnormal rise of temperature for motor and stops the motor automatically. It prevents the motor from burning.

SINGLE PHASE ELECTRIC TROLLEY MODEL: MTS

Single phase model. This trolley can be combined with SA.

In case of combination with SA, you can operate by 4 push buttons.



FEATURES OF FA/FB/SA

1 Tough, heavy-duty motor.

Originally designed motor with low power consumption.

	Insulation class	Short time duty
FA	E	30 minutes
FB	E	30 minutes (high speed)
		15 minutes (low speed)
SA	B	25 minutes

2 Reliable electro-magnetic DC brake

3 Highly durable load chain of our own manufacture.

4 Totally enclosed steel plate construction

Wiring:simple plug-in type connection of wires.

5 Top and bottom hook with high safety and operability

Bottom hook with bearing swivels 360° smoothly. In case of overloading, it gradually elongates without fracture.

6 Chain bucket

Specially strengthened plastic bucket.

7 Limit switch

Standard model is equipped with limit switch.

Combination of FA/FB/SA with monorail and crane

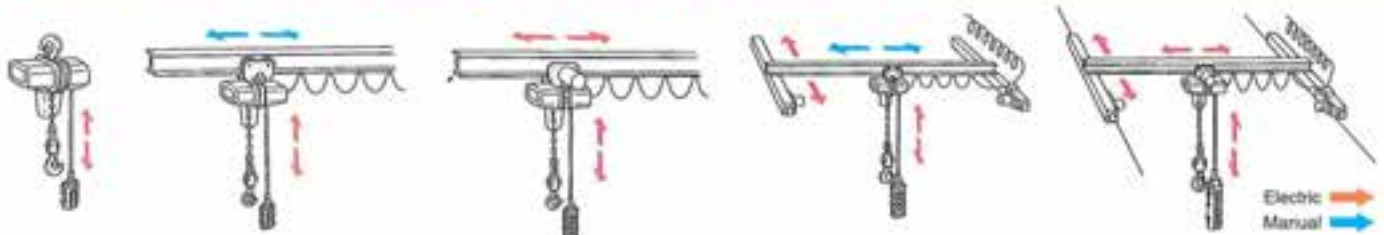

FA/FB/SA
+2 push buttons
+5m power cord

FA/FB/SA
+Geared/Plain trolley
+2 push buttons
+5m power cord

FA/FB/SA
+Electric trolley
+4 push buttons

FA/FB/SA
+Geared/Plain trolley
+4 push buttons
+ SBA (crane wiring box)

FA/FB
+Electric trolley
+6 push buttons
+SBA (crane wiring box)



FA/FB(3 phase) Hook suspension

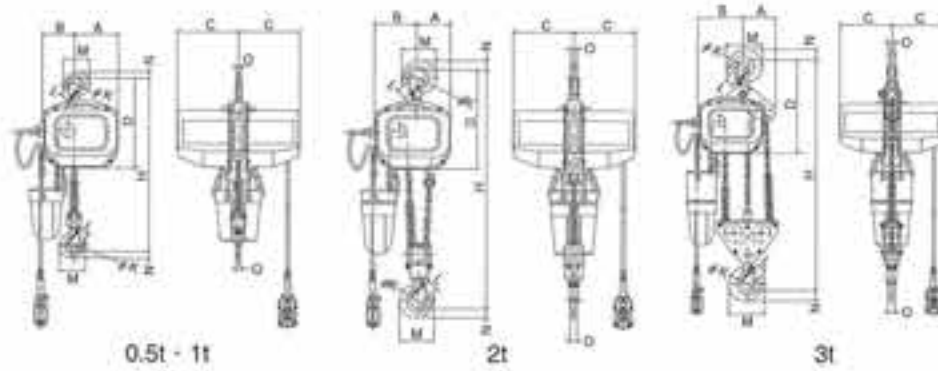

SPECIFICATION

Model No.	W.L.L. (ton)	Test load (ton)	Standard lift(m)	Standard push button cord length(m)	load chain dia x number of falls	Lifting motor output, FB/High/Low speed		Lifting speed(m/min) FB/High/Low speed		Minimum distance H(mm)	Net weight
						50Hz	60Hz	50Hz	60Hz		
FA-0.5	0.5	0.625	3	2.5	6.3x1	0.9	7.0	8.4	555	43(46)	
FA-1	1	1.25	3	2.5	7.1x1	1.6	6.3	7.5	590	56(60)	
FA-2	2	2.5	3	2.5	7.1x2	1.6	3.1	3.8	745	64(71)	
FA-3	3	3.75	4	3.5	7.1x3	1.6	2.1	2.5	840	83(90)	
FB-0.5	0.5	0.625	3	2.5	6.3x1	0.9:0.25	7.0:1.8	8.4:2.1	555	44(47)	
FB-1	1	1.25	3	2.5	7.1x1	1.6:0.4	6.3:1.6	7.5:1.9	590	57(61)	
FB-2	2	2.5	3	2.5	7.1x2	1.6:0.4	3.1:0.8	3.8:0.9	745	65(72)	
FB-3	3	3.75	4	3.5	7.1x3	1.6:0.4	2.1:0.5	2.5:0.6	840	84(91)	

1)The number bracketed in "Net weight" indicates 6m lift. 2)The length of power cord is 4 core-0.5m(standard).

DIMENSIONS

W.L.L.(ton)	A	B	C	D	K	L	M	N	O
0.5t	161	124	224	316.5	43	26.5	84	19	14
1t	170	128	239	349	50	31	103	25	19
2t	133	165	239	386.5	65	38	135.5	35	26
3t	148	208	239	427	60	43	165	49	32



FAMB/FBMB(3 phase) Electric chain block with electric trolley

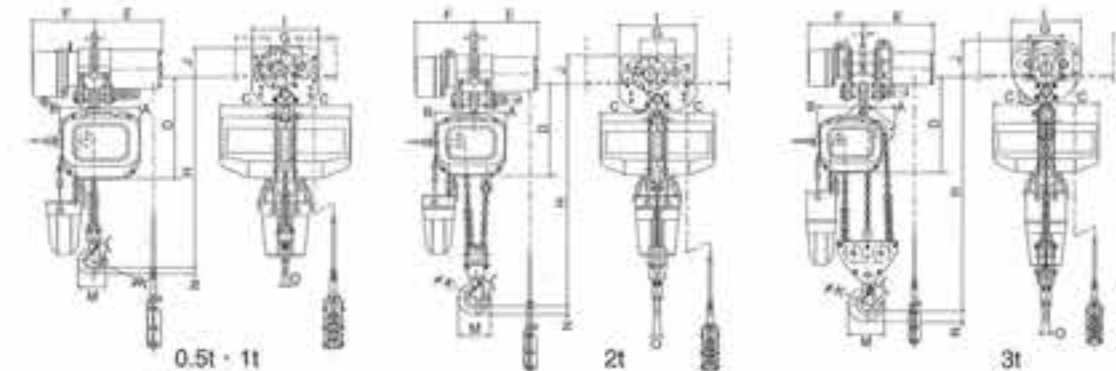

SPECIFICATION

Model No.	W.L.L. (ton)	Standard lift(m)	Lifting speed(m/min) (FB)High/Low speed	Traversing motor output (kw)	Traversing speed(m/min)		Minimum distance H(mm)	Traversing I beam width	Trolley min radius(mm)	Net weight	
					50Hz	60Hz					
FAMB-0.5	0.5	3	7.0	8.4	0.4	5:20 (MB type)	6:24 (MB type)	695(600)	75-100	1100	74(77)
FAMB-1	1	3	6.3	7.5							
FAMB-2	2	3	3.1	3.8							
FAMB-3	3	4	2.1	2.5							
FBMB-0.5	0.5	3	7.0:1.8	8.4:2.1	0.4	5:20 (MB type)	6:24 (MB type)	695(600)	75-100	1100	75(78)
FBMB-1	1	3	6.3:1.6	7.5:1.9							
FBMB-2	2	3	3.1:0.8	3.8:0.9							
FBMB-3	3	4	2.1:0.5	2.5:0.6							

1)The number bracketed in "Net weight" indicates 6m lift. 2)The length of power cord in standard is 4 core-0.5m in case of 4 push button, 7 core-0.5m in case of 6 push button. 3)When you need 6 push button for crane instead of 4 push button, "C" should be added to the end of model name. 4)Short time duty for MB is 15 minutes. 5)Minimum distance H is in case of that "Traversing I beam width" is minimum. 6)The number bracketed in "Minimum distance H(mm)" means direct connection.

DIMENSIONS

W.L.L.(ton)	A	B	C	*D	*E	*F	G	I	*J	K	L	M	M	N	O	φ P(diameter of wheel)
0.5t	161	124	224	456.5	251(278)	218.5	120	246	114	43	26.5	84	19	14	68	
1t	170	128	239	489	251(278)	218.5	120	246	114	50	31	103	25	19	68	
2t	133	165	239	550	267(294)	247	148	324	137	65	38	135.5	35	26	83.5	
3t	148	208	239	582	324(400)	252	160	316	181	60	43	165	49	32	98	

1)Dimension marked by "*" is in case of that "Traversing I beam width" is minimum.



FAM/FBM(3 phase) Electric chain block with electric trolley

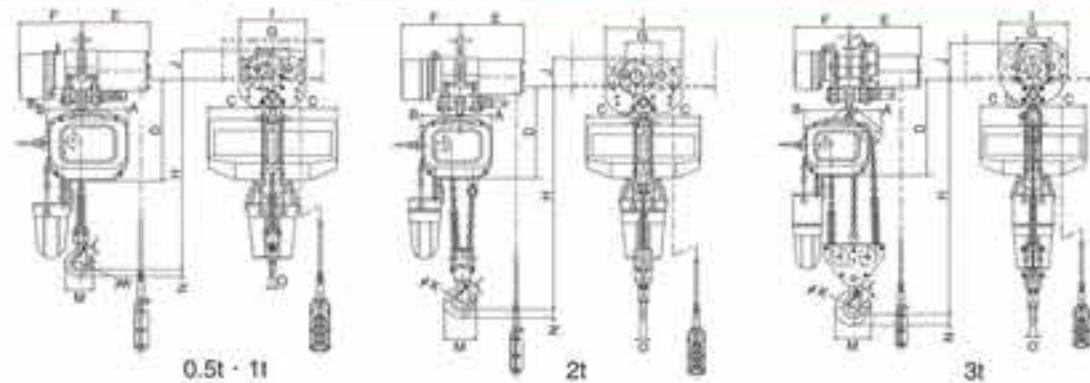

SPECIFICATION

Model No.	W.L.L. (ton)	Standard lift(m)	Lifting speed(m/min) (FB)High/Low speed		Traversing motor output (kw)	Traversing speed(m/min)		Minimum distance H(mm)	Traversing I beam width	Trolley min radius(mm)	Net weight
			50Hz	60Hz		50Hz/60Hz	50Hz/60Hz				
FAM-0.5	0.5	3	7.0	8.4	0.4	20/24 (MAF type)	10/12 (MAS type)	695(600)	75-100	1100	74(77)
FAM-1	1	3	6.3	7.5							
FAM-2	2	3	3.1	3.8							
FAM-3	3	4	2.1	2.5							
FBM-0.5	0.5	3	7.0:1.8	8.4:2.1	0.4	20/24 (MAF type)	10/12 (MAS type)	695(600)	75-100	1100	75(78)
FBM-1	1	3	6.3:1.6	7.5:1.9							
FBM-2	2	3	3.1:0.8	3.8:0.9							
FBM-3	3	4	2.1:0.5	2.5:0.6							

1)The number bracketed in "Net weight" indicates 6m lift. 2)The length of power cord in standard is 4 core-0.5m in case of 4 push button, 7 core-0.5m in case of 6 push button. 3)When you need 6 push button for crane instead of 4 push button, "C" should be added to the end of model name. 4)Short time duty for MAF/MAS is 30 minutes. 5)Minimum distance H is in case of that "Traversing I beam width" is minimum. 6)The number bracketed in "Minimum distance H(mm)" means direct connection.

DIMENSIONS

W.L.L.(ton)	A	B	C	*D	*E	*F	G	I	*J	K	L	M	N	O	φ P(diameter of wheel)
0.5t	161	124	224	456.5	251(278)	218.5	120	246	114	43	26.5	84	19	14	68
1t	170	128	239	489	251(278)	218.5	120	246	114	50	31	103	25	19	68
2t	133	165	239	550	267(294)	247	148	324	137	65	38	135.5	35	26	83.5
3t	148	208	239	582	324(400)	252	160	316	181	60	43	165	49	32	98

1)Dimension marked by "*" is in case of that "Traversing I beam width" is minimum.

※The specification and dimensions may be changed without prior notice for improvement.

FAG, FAP/FBG, FBP type Electric chain block with geared/plain trolley

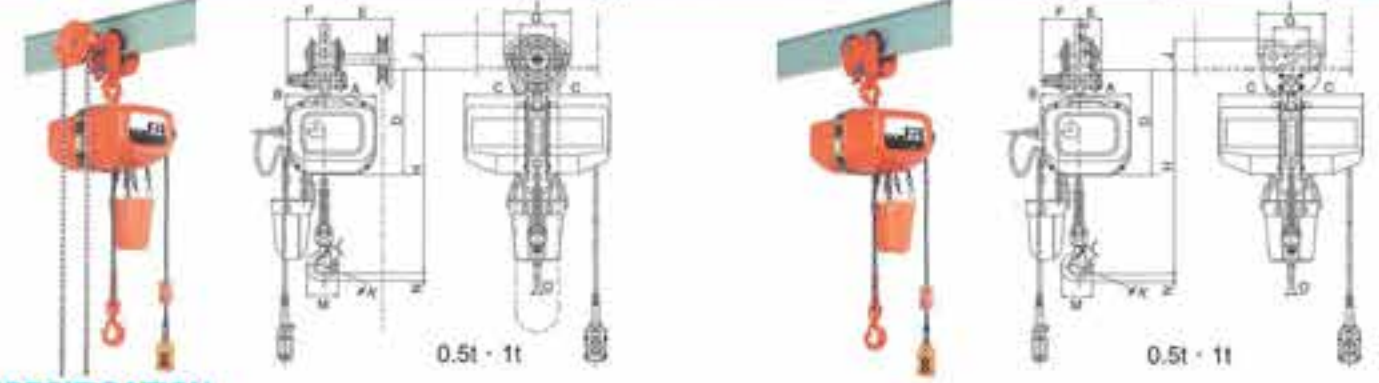

SPECIFICATION

Model No.	W.L.L. (ton)	Standard lift(m)	Lifting speed(m/min) (FB)High/Low speed		Traversing motor output (kw)	Traversing speed(m/min)		Minimum distance H(mm)	Traversing I beam width	Trolley min radius(mm)	Net weight	
			50Hz	60Hz		50Hz/60Hz	50Hz/60Hz				Geared trolley	Plain trolley
FAG-0.5,FAP-0.5	0.5	3	7.0	8.4	0.4	115	2	670(575)	75-100	800	57(60)	57(60)
FAG-1, FAP-1	1	3	6.3	7.5								
FAG-2, FAP-2	2	3	3.1	3.8								
FAG-3, FAP-3	3	4	2.1	2.5								
FBG-0.5,FBP-0.5	0.5	3	7.0:1.8	8.4:2.1	0.4	115	2	670(575)	75-100	900	58(61)	58(61)
FBG-1, FBP-1	1	3	6.3:1.6	7.5:1.9								
FBG-2, FBP-2	2	3	3.1:0.8	3.8:0.9								
FBG-3, FBP-3	3	4	2.1:0.5	2.5:0.6								

1)The number bracketed in "Net weight" indicates 6m lift. 2)The length of power cord in standard is 4 core-0.5m in case of 2 push button, 7 core-0.5m in case of 4 push button. 3)When you need 4 push button for crane instead of 2 push button, "C" should be added to the end of model name. 4)Minimum distance H is in case of that "Traversing I beam width" is minimum. 5)The number bracketed in "Minimum distance H(mm)" means direct connection.

DIMENSIONS

W.L.L. (ton)	A	B	C	D	Geared/Plain trolley			K	L	M	N	O	φ P (diameter of wheel)	
					E	F	G							
0.5t	161	124	224	431.5	219/76	126	100.4	190.4	43	26.5	84	19	14	70
1t	170	128	239	464	219/76	126	116	221	50	31	103	25	19	80
2t	133	165	239	538.5	237/94	143	136	259	65	38	135.5	35	26	98
3t	148	208	239	597.5	236/96.5	144	150	288	60	43	165	49	32	115

※The specification and dimensions may be changed without prior notice for improvement.

SA type(single phase) Hook suspension

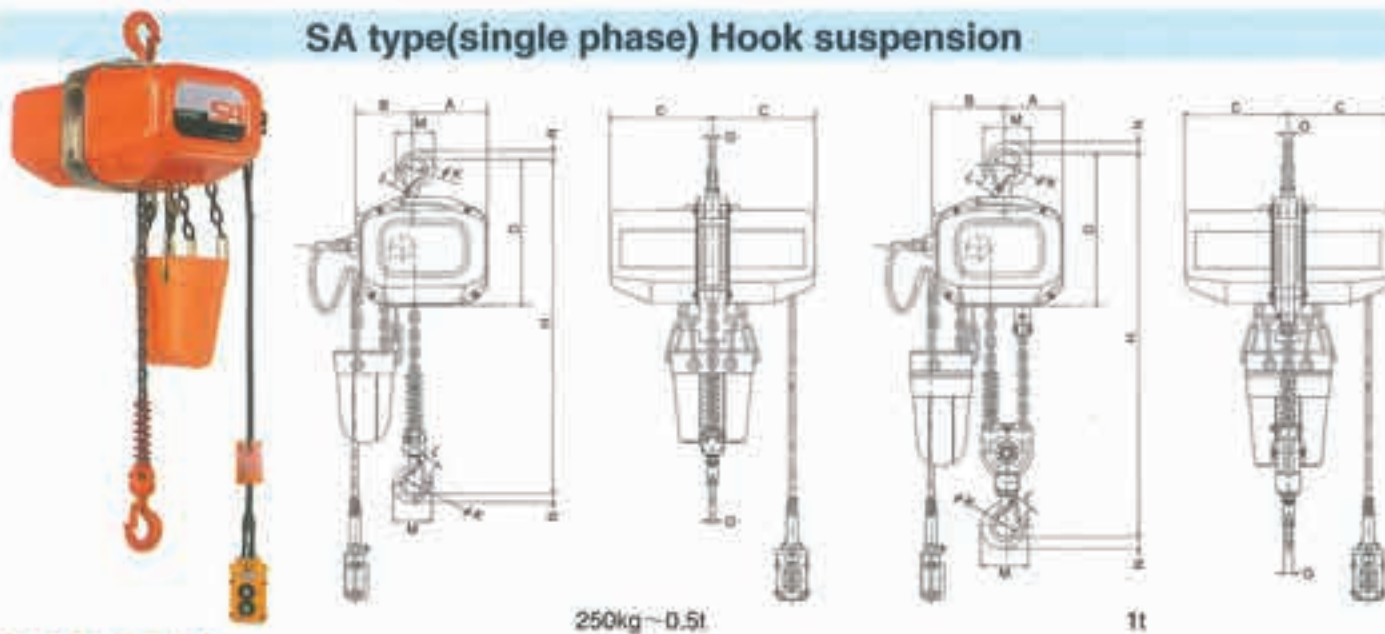

SPECIFICATION

Model No.	W.L.L. (ton)	Test load (ton)	Standard lift(m)	Standard push button cord length(m)	load chain dia x number of falls	Lifting motor output(kw)	Lifting speed(m/min)		Minimum distance H(mm)	Net weight
							50Hz	60Hz		
SA-0.25	250kg	312.5kg	3	2.5	6.3x1	0.45	7.0	8.4	555	43(46)
SA-0.5	0.5	0.625	3	2.5	6.3x1	0.45	3.5	4.1	555	43(46)
SA-1	1	1.25	3	2.5	6.3x2	0.45	1.8	2.1	670	46(52)

1)The number bracketed in "Net weight" indicates 5m lift.
2)The length of power cord is 4 core-5m(standard).

DIMENSIONS

W.L.L.(ton)	A	B	C	D	K	L	M	N	O
250kg	161	124	224	311	43	26.5	84	19	14
0.5t	161	124	224	311	43	26.5	84	19	14
1t	127	158	224	329.5	50	31	103	25	19

SAG, SAP type Electric chain block with geared/plain trolley

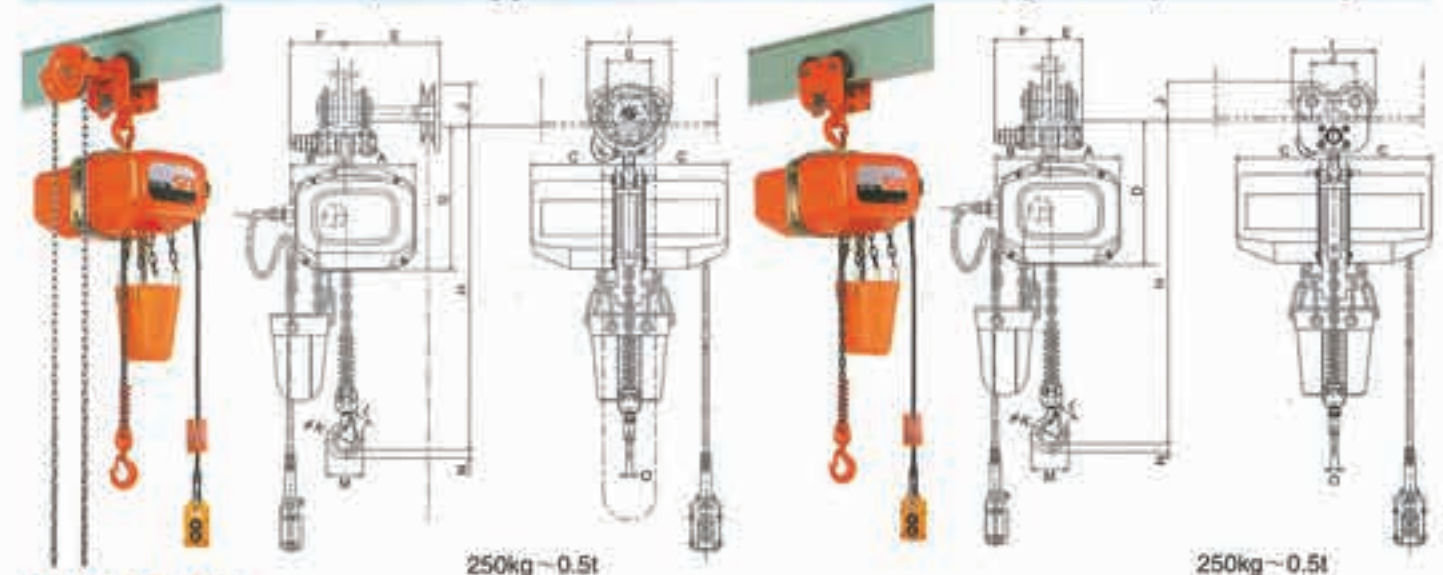

SPECIFICATION

Model No.	W.L.L. (ton)	Standard lift(m)	Lifting speed(m/min)		Trolley Traversing distance in rail to hand diameter	Geared trolley Hand chain effort (approx.)(kg)	Minimum distance H(mm)	Traversing beam width	Trolley min radius(mm)	Net weight	
			50Hz	60Hz						w/Geared trolley	w/Plain trolley
SAG-0.25/SAP-0.25	0.25	3	7.0	8.4	115	1	670(575)	75	900	57(60)	51(54)
SAG-0.5, SAP-0.5	0.5	3	3.5	4.1	115	2	670(575)	100	900	57(60)	51(54)
SAG-1, SAP-1	1	3	1.8	2.1	94	3.5	785(680)	125	1100	65(71)	59(65)

1)The number bracketed in "Net weight" indicates 5m lift. 2)The length of power cord in standard is 4 core-5m in case of 2 push button.
3)Minimum distance H is in case of that "Traversing beam width" is minimum. 4)The number bracketed in "Minimum distance H(mm)" means direct connection.

DIMENSIONS

W.L.L. (ton)	A	B	C	D	Geared/Plain trolley			K	L	M	N	O	φP (diameter of wheel)		
					E	F	G								
250kg	161	124	224	431.5	219/76	126	100.4	190.4	102/94	43	26.5	84	19	14	70
0.5t	161	124	224	431.5	219/76	126	100.4	190.4	102/94	43	26.5	84	19	14	70
1t	127	158	224	445	219/76	126	116	221	120.5/106.5	50	31	103	25	19	80

SAM type(single phase) Electric chain block with electric trolley

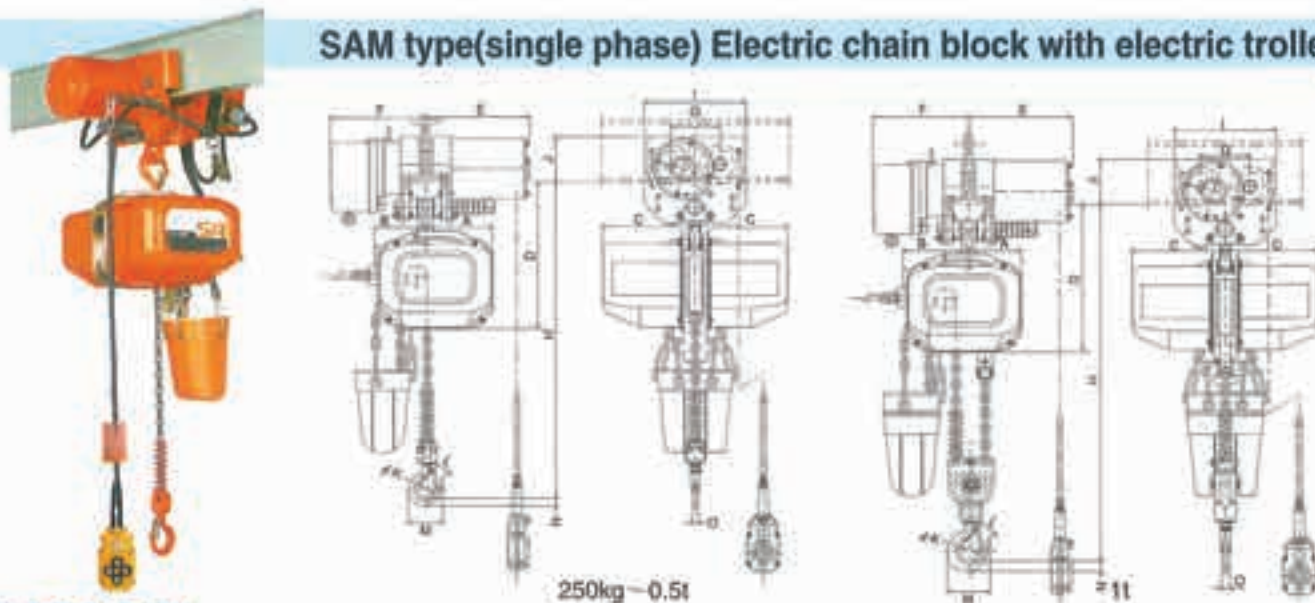

SPECIFICATION

Model No.	W.L.L. (ton)	Test load (ton)	Standard lift(m)	Traversing motor output (kw)	Lifting speed(m/min)		Traversing speed(m/min) 50Hz/60Hz	Minimum distance H(mm)	Traversing beam width	Trolley min radius (mm)	Net weight
					50Hz	60Hz					
SAM-0.25	250kg	312.5kg	3	0.3	7.0	8.4	10/12 (MTS type)	695(600)	75	1100	74(77)
SAM-0.5	0.5	0.625	3		3.5	4.1		695(600)	100	1100	74(77)
SAM-1	1	1.25	3		1.8	2.1		810(705)	125	1100	77(83)

1)The number bracketed in "Net weight" indicates 5m lift.
2)The length of power cord in standard is 4 core-0.5m in case of 4 push button.
3)Short time duty for MTS is 15 minutes.
4)Minimum distance H is in case of that "Traversing beam width" is minimum.
5)The number bracketed in "Minimum distance H(mm)" means direct connection.

DIMENSIONS

W.L.L.(ton)	A	B	C	D	E	F	G	I	J	K	L	M	N	O	φP(diameter of wheel)
250kg	161	124	224	456.5	251	218.5	120	246	114	43	26.5	84	19	14	68
0.5t	161	124	224	456.5	251	218.5	120	246	114	43	26.5	84	19	14	68
1t	127	158	224	531	251	218.5	120	246	114	50	31	103	25	19	68

※The specification and dimensions may be changed without prior notice for improvement.

Emergency stop button

Option Available for all models.



Cable hanger

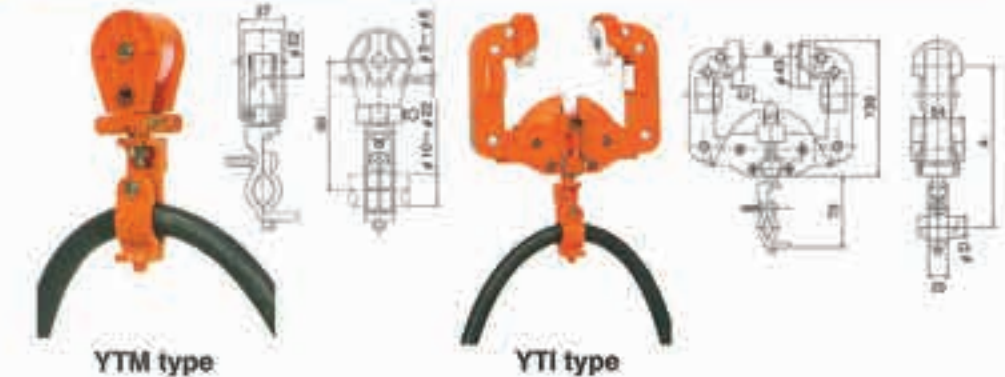

DIMENSIONS

Model	beam width	A	B	C	D
YTI-100	75	166	32	15	φ10-22
YTI-100	100	166	57	15	φ10-22
YTI-150	125	166	82	25	φ10-22
YTI-150	150	166	107	25	φ10-22